

Genie® GR-12, GR-15 & GR-20

Specifications

Models	GR-12	GR-15	GR-20
Working height max. - indoor ⁽¹⁾	5.45 m	6.47 m	8.02 m
Working height max. - outdoor ⁽¹⁾	4.80 m	5.40 m	6.70 m
Platform height max. - indoor	3.45 m	4.47 m	6.02 m
Platform height max. - outdoor	2.80 m	3.40 m	4.70 m
A B Platform dimensions (lengthxwidth) - Standard retracted	0.89×0.75 m	0.89×0.75 m	0.89×0.75 m
Platform dimensions (lengthxwidth) - Standard extended	1.4×0.75 m	1.4×0.75 m	1.4×0.75 m
C Height - stowed	1.78 m	1.78 m	1.98 m
D Length- stowed	1.35 m	1.35 m	1.35 m
E Width	0.75 m	0.75 m	0.80 m
F Ground clearance (center)	6 cm	6 cm	6 cm

Productivity

Maximum platform occupancy (in/out)	1/1	1/1	1/1
Lift capacity	227 kg	227 kg	159 kg
Lift capacity - extension deck extended	113 kg	113 kg	113 kg
Drive speed - stowed	4.0 km/h	4.0 km/h	4.0 km/h
Drive speed - raised	0.8 km/h	0.8 km/h	0.8 km/h
Gradeability ⁽²⁾	30 %	30 %	30 %
Turning radius - inside	0 cm	0 cm	0 cm
Turning radius - outside	1.32 m	1.32 m	1.32 m
Lifting speed - raise/lower	20/18 sec	21/19 sec	24/21 sec
Controls - proportional	24V DC	24V DC	24V DC
Tires - Solid non-marking	25×8×20 cm	25×8×20 cm	25×8×20 cm
Tilt sensor activation (front to back/side to side)	3°/1.5°	3°/1.5°	3°/1.5°

Power

Power	24V (4×6V 225Ah)	24V (4×6V 225Ah)	24V (4×6V 225Ah)
Hydraulic tank capacity	8.33 L	8.33 L	8.33 L

Weight(3) and Floor Loading⁽⁴⁾

Weight	763 kg	988 kg	1,140 kg
Tire load max.	308 kg	327 kg	395 kg
Tire contact pressure	721.3 Kpa	763.7 Kpa	922.8 Kpa
Occupied floor pressure	9.6 kPa	12.1 kPa	12.0 kPa

Sound and Vibration Levels

Sound Pressure level (ground workstation)	< 70 dBA	< 70 dBA	< 70 dBA
Sound Pressure level (platform workstation)	< 70 dBA	< 70 dBA	< 70 dBA
Vibrations	< 2.5 m/s ²	< 2.5 m/s ²	< 2.5 m/s ²

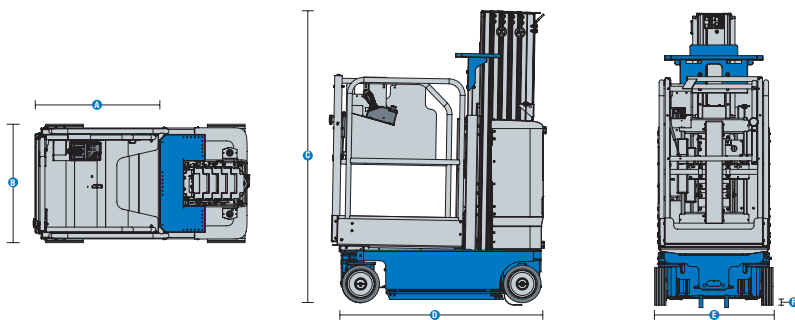

(1) The metric equivalent of working height adds 2 m to platform height. U.S. adds 6 ft to platform height.

(2) Gradeability applies to driving on slopes and may vary depending on options and machine configurations. See operator's manual for details regarding slope ratings.

(3) Weight refers to standard configuration and may vary depending on options and/or country standards.

(4) Floor loading information is approximate and may vary depending on options and machine configurations. It should be used only with adequate safety factors.

Genie® GR-12, GR-15 & GR-20

SKU: Standard Model

- GR-12*
- GR-15*
- GR-20*

* Build to Order

Option availability		S	S+	BtO
Power	Standard FLA flood lead acid batteries			✓
	AGM maintenance-free batteries			○
Platform	Sliding mid-rail standard aluminum platform			✓
	Sliding mid-rail extension aluminum platform			○
	Gated extension aluminum platform			○
	Automotive-style horn			○
	Lift Tools Work Tray			○
	AC power to platform			✓
	Auxiliary platform lowering			✓
	Platform control guard			✓
	Platform load sense system			✓
	Proportional lift and drive			✓
	SmartLink dual zone control system			✓
Chassis	Lift Connect Telematics			○
	Lift Connect with Access Manager upgrade			○
	Biodegradable hydraulic oil			○
	Drive cut-out while charging			○
	Lift Guard White Noise Alarm			○
	Descent, tilt, and motion alarm			✓
	Dual LED flashing beacons			✓
	Dual wheel multi-disc brakes			✓
	Hinged rear ABS covers for easy access			✓
	Hour meter			✓
	Hydraulic brake release			✓
	Large forklift pockets access			✓
	Lift Tools Spill Guard			✓
	On-board diagnostic system with battery charge indicator			✓
	Overhead crane attachment point			✓
	Pothole protection			✓
	Solid non-marking tires			✓
Tech Pro Link connector			✓	
Tie-down attachment points			✓	

- S Standard
- S+ Standard +
- BtO Build to Order
- ✓ Standard Features
- Options



Zero Inside Turning Radius



Narrow Access



Low Entry Height

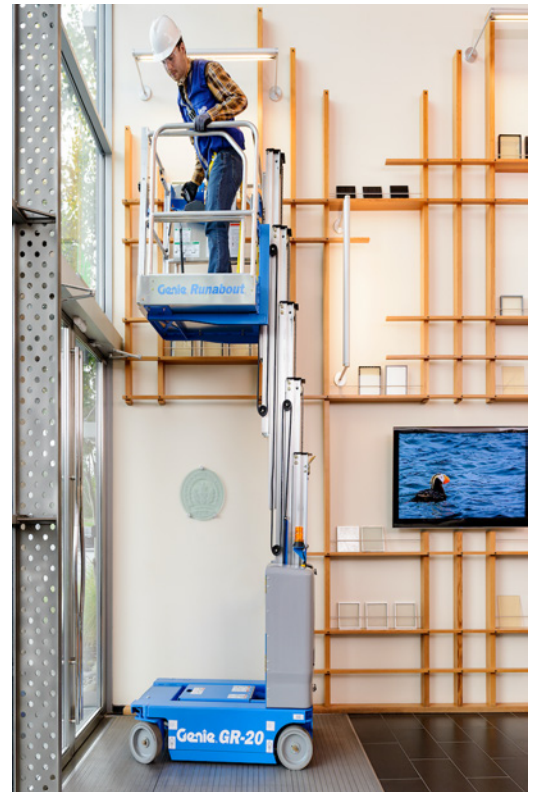

Genie Genuine Accessories⁽¹⁾

- Lift Tools productivity tools
- Lift Connect Telematics subscription extension
- Tech Pro Link Connector

(1) More accessories available from Genie Genuine Parts.

Product specifications are subject to change without notice or obligation. Photographs and/or drawings herein are for illustrative purposes only. Refer to the appropriate Operator's Manual for instructions on proper equipment use. Failure to follow instructions in the Operator's Manual may result in serious injury or death. The only warranty applicable to our equipment is the standard written warranty applicable to the particular product and sale and we make no other warranty, express or implied. Products and services listed may be trademarks, service marks or trade names of Terex Corporation and/or their subsidiaries in the USA and many other countries. Terex, Genie, Quality By Design, Xtra Capacity, Lift Power, Lift Guard, Lift Tools, Lift Connect and Tech Pro Link are registered trademarks of Terex Corporation or its subsidiaries.